

Company presentation Fiberpipe GmbH

FIBERPIPE GmbH distributes high-performance products, compound of fibreglass and thermosetting resin, through the registered trademark Chemcast and FIBERPIPE. FIBERPIPE offers the products of the most renowned manufacturers e.g. Fiberglass Systems and others.

The combined experiences of our partner companies equal more than 100 years. Whatever you need, we are able to offer you the whole range of GRP-products. From a filament wound pipe DN 25 up to a double wall vessel DN 8000, we are your exclusive partner. We use all kind of resins and have the exclusive distribution rights for centrifugal cast pipes in Germany, Austria and Switzerland.

Following our philosophy we deliver up to DN 300 directly from our stock in Stolberg. The installation of pipelines is a short-term business with ever changing market conditions. For this reason all our pipes and fittings have standard ISO dimensions. This has the advantage that all fittings are compatible with all pipe systems. We also offer you the construction of special parts, almost everything of which a mould can be built and applied with GRP.

Our partners are qualified for their high standards of their products, services and manufacturing. So we can ensure that we distribute the best and most favourable products. The many years of experience of our partners offers us for all recommended applications the necessary references or case histories. The continuous improvement and development of our partners ensure that no innovations stay hidden.

What is GRP?

Fiberpipe pipe systems consist of different raw materials complementing one another. These materials are different kind of glass fabrics, glass mats and thermosetting resins. By combining the materials a “division of labour” happens. The mechanical properties e.g. tensile strength, pressure resistance and E-Module are defined by the quantity and glass type used. The choice of resin determines the chemical resistance and temperature rating of the compound. As no other kind of material offers the same flexibility in cutting pipes or adding a support, Fiberpipe pipe systems are again setting standards for installation costs. Flexible, cost effective installation and pipe value of the Fiberpipe pipe systems do offer you a very attractive investment.

Applications and installations:

Diameters ranging between DN 25 and DN 2000, pressures up to 40 bars plus the possibility to adapt the material to almost any condition: Fiberpipe pipe systems offer an alternative to almost any kind of required material.

Ease of installation, light weighted and flexible handling make our piping systems very interesting for installation companies as well as for the end user. As an application indication, we compiled a list of standard applications as used in most industries.

Other applications of our piping systems are offered; together we can take into consideration the possibilities of our pipes for your individual requirements.

Standard implementations are:

Chemical industry:

Water supply lines (process water, cooling water, industrial water)

Vent lines

Floor drains

Sludge & slurry lines

Acid handling

Chlorine & caustic

Brine slurry

Chemical feed lines

Waste drain and water treatment

Condensate return lines

Product pipelines

Underground fire-extention pipelines

Scrubber headers

District heating:

Heat exchange supply

Domestic water supply

Cooling tower supply

Condensation pipelines

Heating water supply

Naval industry:

Wet and dry fire protection systems

Column piping for vertical turbine

Process water, cooling water, industrial water

Condensate pipelines

Floor drains

Sanitary systems (black and grey water)

Ballast water systems

Water purification systems

Power plant:

Water supply lines (process water, cooling water, industrial water)
Vent lines
Floor drains
Sludge & slurry lines
Acid handling
Chlorine & caustic
Brine slurry
Chemical feed lines
Waste drain and water treatment
Condensate return lines
Process pipelines
Underground fire-extention pipelines
Scrubber headers

Pulp and paper:

Water supply lines (process water, cooling water, industrial water)
Vent lines
Floor drains
Product pipelines
Acid handling
Chlorine & caustic
Sludge & slurry lines
Brine slurry
Chemical feed lines
Process lines
Waste drain and water treatment
Condensate return lines
Underground fire-extention pipelines
Scrubber headers

as well as several other installations and applications. Just try us.

Fabrication methods:

The production method can be seen as an even important parameter. In principle there are two different possibilities to produce pipes with glass and resin.

Centrifugal Casting Process:

This production process gives you the optimal result for chemical resistance and abrasion.

Woven glass fibre (or fabric), in hoop and axial direction weaved, and glass mat are placed in a motor driven steel tube, rotated (centrifuge) at high speed. Afterwards the resin is injected into the rotating mould. This process results in following advantages:

1. **Highest temperature resistance, because of best resin-impregnated glass fibres**
2. **Highest chemical resistance, because of pure resin chemical barrier with optimum resistance**
3. **Lowest fluid flow loss, because of smooth inside and outside wall**

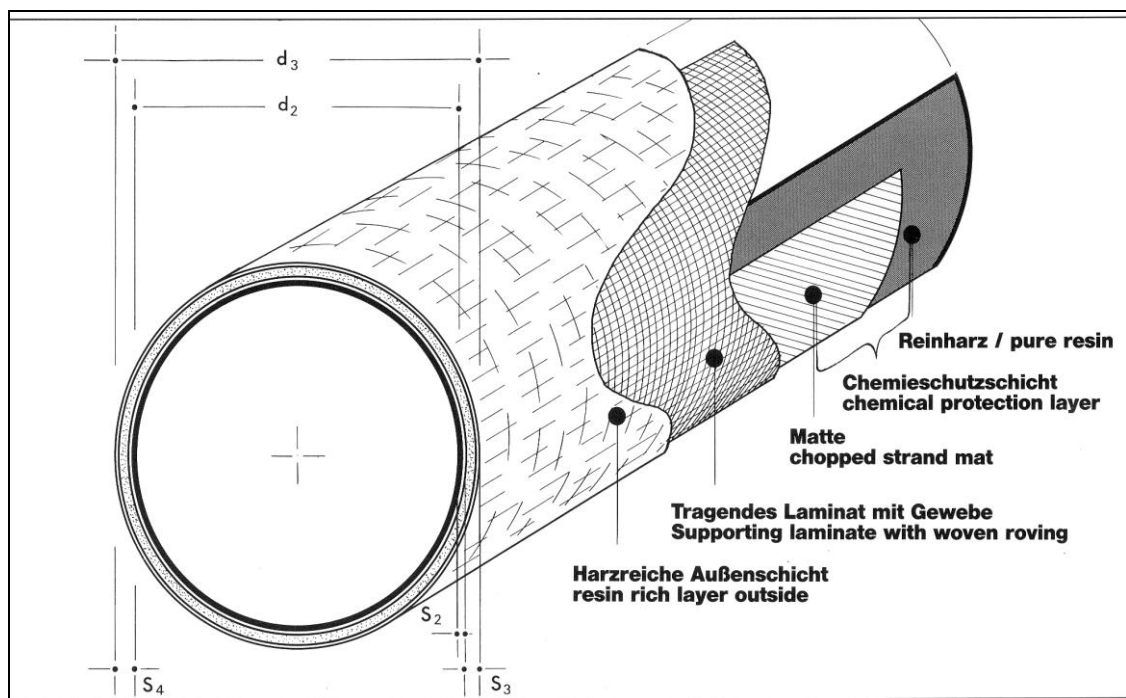

Laminate construction of FIBERPIPE centrifugal cast pipes in epoxy or vinyl ester resin.

A selection of physical properties for Fiberpipe centrifugal cast pipes in epoxy resin and vinylester resin are indicated in the following table:

Mechanical properties at 24°C	Test standard		
Tensile strength, axial	DIN EN ISO 527-1 / 527-4	180	$\frac{N}{mm^2}$
Tensile modulus of elasticity , axial	DIN EN ISO 527-1 / 527-4	18.000	$\frac{N}{mm^2}$
Internal pressure strength, axial	ASTM D 695	180	$\frac{N}{mm^2}$
Internal pressure modulus of elasticity, axial	ASTM D 695	18.000	$\frac{N}{mm^2}$
Internal pressure tangential	ASTM D 1599	180	$\frac{N}{mm^2}$
Internal pressure strength modulus of elasticity, tangential	ASTM D 1599	18.000	$\frac{N}{mm^2}$
Beam bending strength	DIN EN ISO 14125	340	$\frac{N}{mm^2}$
Beam bending modulus of elasticity	DIN EN ISO 14125	13.000	$\frac{N}{mm^2}$
Density		1.470	$\frac{kg}{m^3}$

Filament wound process:

As the fabrication of centrifugal cast pipes greater than DN 350 is not cost effective, another production method has been brought to perfection: the so-called filament winding process.

Resin-impregnated glass fibres (roving) are wound onto a mandrel, in a predetermined pattern and under controlled tension. This process can be optimised by choosing a specific winding angle for particular requirements. (e.g.: for optimum internal pressure capability a winding angle of 54° is chosen). Even for this production process one takes great care to reach the highest possible resin content in the pipe internally

For this purpose, the production process of the pipe starts a glass veil or mat which supports the resin is applied.

1. **low wall thickness, because optimum winding angle is chosen for high stress**
2. **high chemical resistance, because the thickness of the chemical barrier is variable**
3. **favourable alternative to other materials like steel-rubber**

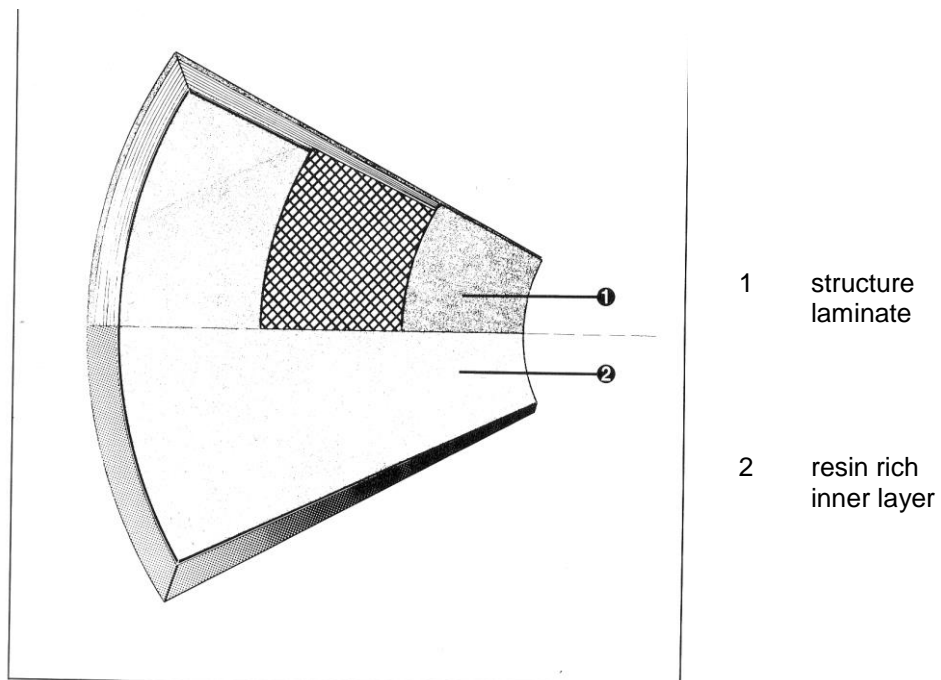

Wall structure of Fiberpipe filament wound pipe in epoxy or vinyl ester resin.

A selection of physical properties for Fiberpipe filament wound pipe in vinyl ester resin is indicated in the following table

Mechanical properties at 24°C	Test standard		
Tensile strength, axial	ASTM D 2105	130	$\frac{N}{mm^2}$
Tensile modulus of elasticity E-module, axial	ASTM D 2105	12500	$\frac{N}{mm^2}$
External pressure strength, axial	ASTM D 695	130	$\frac{N}{mm^2}$
External pressure modulus of elasticity E-module, axial	ASTM D 695	18000	$\frac{N}{mm^2}$
Internal pressure tangential	ASTM D 1599	360	$\frac{N}{mm^2}$
Internal pressure strength modulus of elasticity E-module, tangential	ASTM D 1599	20000	$\frac{N}{mm^2}$
Beam bending strength, tangential	ASTM D 790	100	$\frac{N}{mm^2}$
Beam bending modulus of elasticity E-module, tangential	ASTM D 790	20500	$\frac{N}{mm^2}$
Density		1800	$\frac{kg}{m^3}$

Connection techniques:

The connection of the pipes and fittings must be as efficient as possible, without any extensive hand labour. Almost all connection techniques are applicable for Fiberpipe pipes. The most common techniques are bonding, laminating, and different flange connections.

Bonded connection:

Bonding is the most frequently-used technique for connecting glass fibre reinforced pipeline systems. For this reason pipes will be cut, tapered at bonding areas, adhesive applied, the pipe-end moved into the coupling, fixed and cured with heat blanket.

This quick and economical way of installing pipes has been approved in the last 20 years all over the world.

Laminated connection:

A laminated connection is the classic way to connect GRP parts. The procedure is well known, every body has repaired his car, boat, surfboard or similar with GRP. By this method surfaces are also tapered, impregnated glass mat and woven roving applied. If the target wall thickness is obtained, the laminate dries and after post curing taken into service immediately.

Rubber seal lock:

This type of connection is specially qualified for long pipe lines.

The seal of the joint is ensured by use of an O-ring, and a locking strip keeps the connection secure. The procedure of this application: pipes are pushed together and a preheated locking strip is pressed in to the groove. Also for this type of installation, fittings are connected to the pipe by bonding.

Flange connection:

All type of flanges can be connected to Fiberpipe pipe systems. Fix flange, DIN, ISO, collar and loose flange in GFP, galvanised steel, PP coated or special flanges... all is possible.

Special connections:

Fiberpipe pipe systems are characterized by a wide range of connections. If it is Whether Straub, Mewa, Gruvlock or others, just try us.

Specifications for pipes and fittings in fibreglass reinforced phenacrylic resin (vinyl ester resin) with 2,5 mm chemical barrier

1.0 Specification extent

This specification applies for cross filament wound pipes and fittings in glassfibre reinforced plastics based on thermosetting phenacrylic resin, according DIN 16965 Part 4 with 2,5 mm chemical barrier.

2.0 General operational conditions

The pipe system must be qualified for following operational conditions:

Medium	:
Working pressure	:
Working temperature	:
Hazardous temperature	:
Pressure test	:

All design and calculation methods must take as a basis these operational conditions.

2.1 Quality assurance measures

The Quality Management System of the pipe manufacturer must be in agreement with the specifications of DIN ISO 9001 and the following. Furthermore the production of the pipe manufacturer must comply with the standards of the RAL/GKR guide line. An external quality control is required.

2.2 Storage, transport and handling

Pipes and fittings shall be stored, transported and installed according the processing instructions of the pipe manufacturer.

Connection between pipes or between pipes and fittings are executed in general with cylindrical or conical bell-and-spigot bonded coupling with two component epoxy adhesive.

3.1 Pipe dimensions

Fibreglass reinforced phenacrylic resin (VE) according to DIN 16965 Part 4, constructed in the filament wound process in 3m length (DN25), 6 m (DN40 till DN80) and 6 or 12 m (as of DN100). With one side belled and other side spigot end for bonding with double component epoxy resin adhesive.

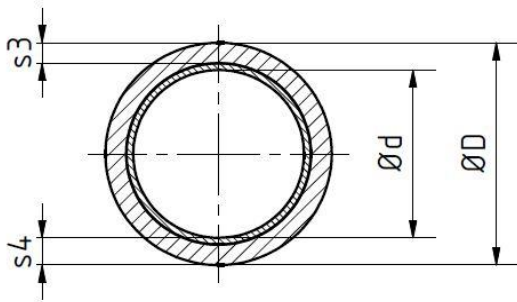

Diameter :
Pressure class :
Wall thickness :
Quantity :

3.2 Fitting dimensions

3.2.1 90° Elbows

Fibreglass reinforced phenacrylic (VE) 90° elbows according to DIN 16966 Part 2 pipe type D, constructed in hand-lay-up process, respectively tape winding with a radius of 1,5x the internal diameter. Cylindrical socket ends, fitted to the pipe system for bonding with a two component epoxy resin adhesive.

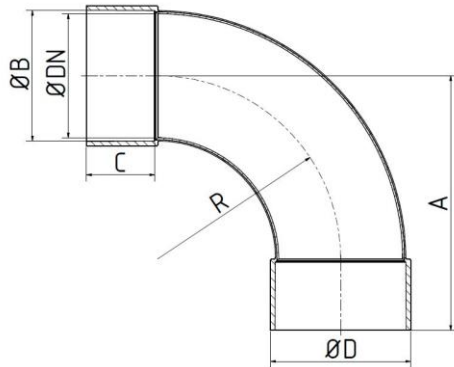

Diameter :
 Pressure class :
 Construction length (A-dimension) :
 Quantity :

3.2.2 45° Elbows

Fibreglass reinforced phenacrylic (VE) 45° elbows according to DIN 16966 Part 2 pipe type D, constructed in hand-lay-up process, respectively tape winding with a radius of 1,5x the internal diameter. Cylindrical socket ends, fitted to the pipe system for bonding with a two component epoxy resin adhesive.

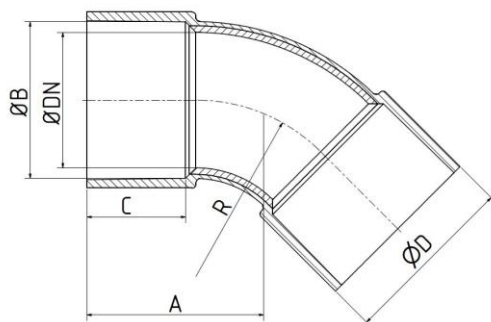

Diameter :
 Pressure class :
 Construction length (A-dimension) :
 Quantity :

3.2.3 Tee

Fibreglass reinforced phenacrylic (VE) Tee according to DIN 16966 Part 4 pipe type D, constructed in hand-lay-up process, respectively tape winding with a radius of 1,5x the internal diameter. Cylindrical socket ends, fitted to the pipe system for bonding with a two component epoxy resin adhesive.

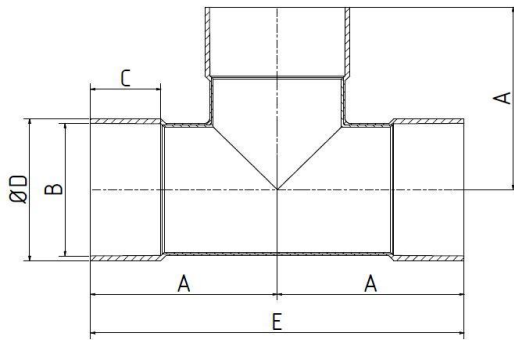

Diameter :
 Pressure class :
 Construction length (A-dimension) :
 Quantity :

3.2.4 Collar

Fibreglass reinforced phenacrylic (VE) Tee according to DIN 16966 Part 6 pipe type D, constructed in hand-lay-up process, respectively roving winding, fitted to the pipe system for bonding with a two component epoxy resin adhesive.

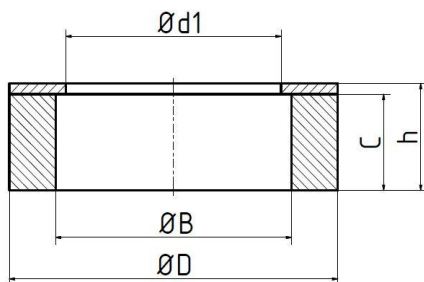

Diameter :
 Pressure class :
 Construction length (h-dimension) :
 Quantity :

3.2.5. Deep galvanised steel loose flange

Deep galvanised steel loose flange DIN/ISO.

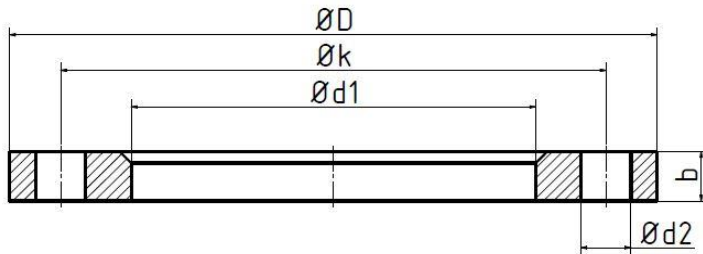

- Diameter :
- Pressure class :
- Construction length (h-dimension) :
- Quantity :
- d 2 :
- Number of holes :
- Quantity :

3.2.6 Concentric reducer

Fibreglass reinforced phenacrylic (VE) concentric reducer according to DIN 16966 Part 6 pipe type D, constructed in hand-lay-up process, respectively tape winding with a radius of 1,5x the internal diameter. Cylindrical socket ends, fitted to the pipe system for bonding with a two component epoxy resin adhesive.

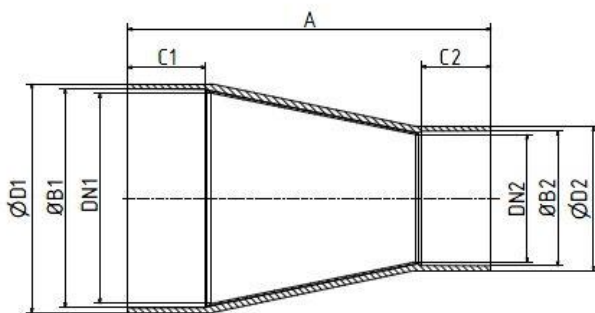

- Diameter :
- Pressure class :
- Construction length (A-dimension) :
- Quantity :